

# SC1232AR3-B-001

# Evaluation Kit for CMOS 24GHz Radar Sensor

## Overview

“The Evaluation Kit (EVK), SC1232AR3-B-001, provides an evaluation environment of the Socionext 24GHz Radar Sensor (SC1232AR3). The EVK consists of EVK main unit (sensor board and interface board), accessory, and the software package which is to be used under the host windows OS PC connected with the EVK via a USB cable.

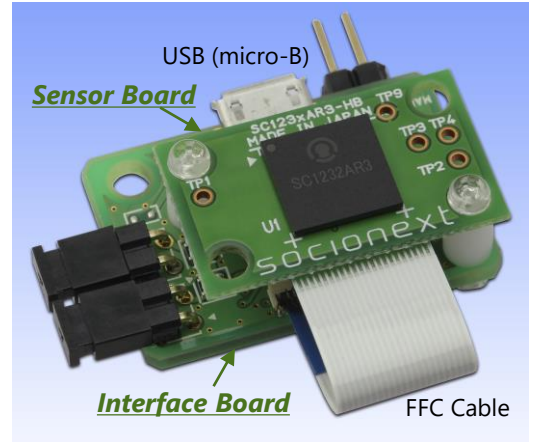

Evaluation Kit of SC1232AR3

## Functions

- Three detection modes :
  1. Entry Motion Detection : Detects a motion of target objects entrance to the detectable area.
  2. Presence Detection : Detects a motion in the detection target area.
  3. Distance Detection : Detects distances to the detected target objects.
- In each detection mode, the detection angle can be selected from two types, “Wide” and “Narrow”.
- Motion detection result (via DETOUT pin) and distance detection result (via SPI interface) are transmitted to the host PC via USB.
- GUI based evaluation software :
  - Detection result can graphically be plotted in the GUI application window.
  - Result data can be saved to a file, and the saved file can be loaded, and plot can be replayed.

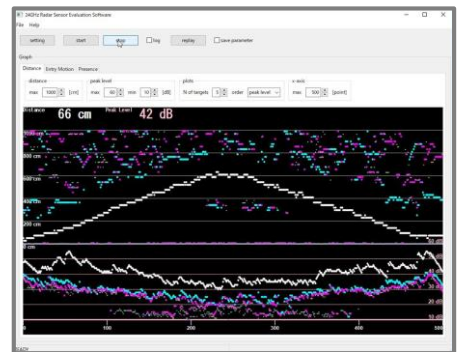

Plot of distance (Upper white-line)  
\* Vertical-axis: Distance from sensor, Horizontal-axis: Time

## EVK System Structure

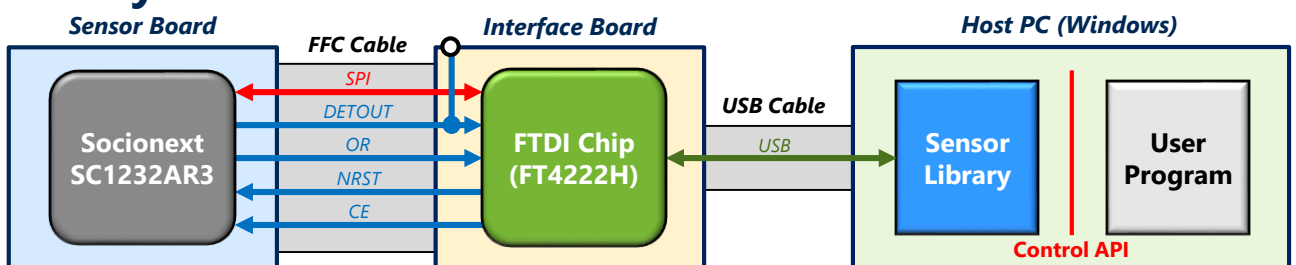

## ■ Specifications

<b>Frequency</b>	24.06 - 24.24GHz
<b>Sensing mode</b>	FMCW* <sup>1</sup> (Up-chirp: 180MHz width) <ul style="list-style-type: none"> <li>• Chirp time (Tc) : 220μsec, 1.1msec, 4.4msec</li> <li>• Chirp interval : <ul style="list-style-type: none"> <li>- 16msec to 5000msec (Tc=220μsec, 1.1msec)</li> <li>- 20msec to 5000msec (Tc=4.4msec)</li> </ul> </li> </ul>
<b>Output (API)</b>	<ul style="list-style-type: none"> <li>• Motion detection result (Entry motion detection/ Presence detection mode)</li> <li>• Distance data derived from the peak frequency component after FFT processing of the received wave (Distance detection mode)</li> </ul>
<b>Interface</b>	USB (micro-B)
<b>Power supply</b>	USB bus power

\*1: Frequency Modulated Continuous Wave

## ■ Contents of EVK Software

- **Sensor Library:**  
A library (DLL) to operate the sensor LSI.
- **Parameter Setting Library:**  
A library (DLL) to maintain the sensor setting parameters.
- **Evaluation GUI Software:**  
A GUI based Windows application to operate the sensor LSI and to display the sensing results.
- **Sample C source codes:**  
Example C source codes for users.

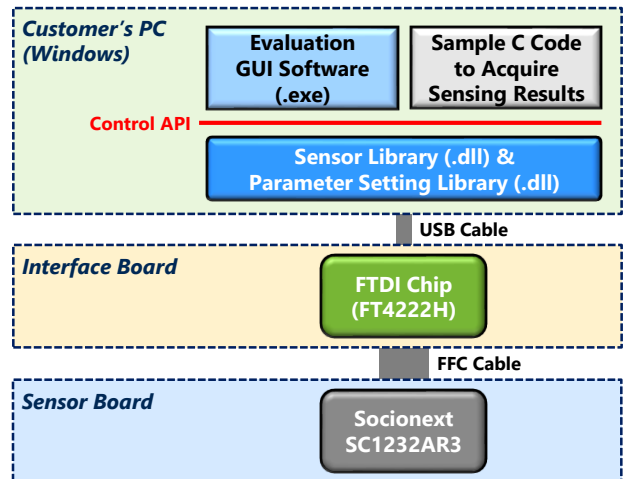

## ■ Measurement environment using EVK

**Setting** : Connects the sensor board to the interface board by a FFC cable. And connects the interface board to the host PC with evaluation software installed by a USB cable.

**Notes** : In order to detect objects on the ground, the EVK should be faced to the detection target area, for example, placing it on the wall or with a supporter like a tripod stand.

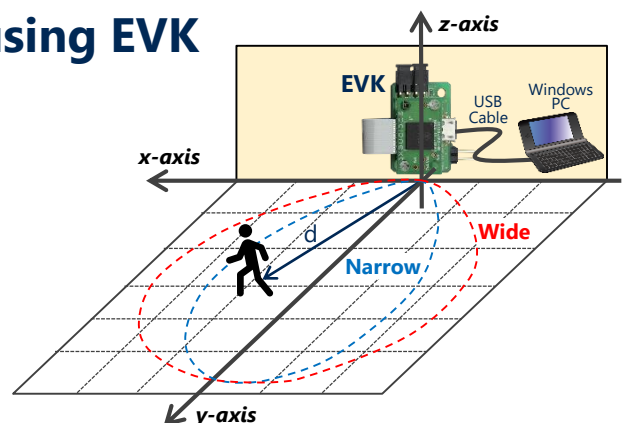

The Products and product specifications described in this document are subject to change without notice for modification and/or improvement. At the final stage of your design, purchasing, or use of the products, therefore, ask for the most up-to-date Product Standards in advance to make sure that the latest specifications satisfy your requirements. All company names, brand names and trademarks herein are property of their respective owners.

Copyright 2020 Socionext Inc.  
August 2020  
Edited: Smart Sensor Solution Team

**Socionext Inc.**

19 Nishikujo-Kasuga-cho,  
Minami-ku, Kyoto, 601-8413, Japan  
Tel. +81-075-778-8011  
<http://socionext.com>